

DIAMETER OF ROUND EL 8 $\frac{1}{8}$ "

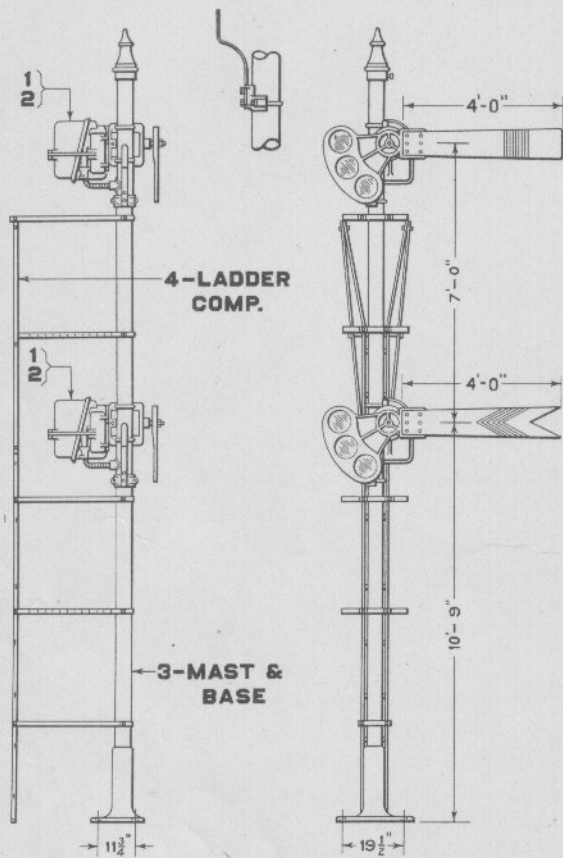

- A - WITH 8 VOLT MECHANISM
- B - WITH 10 VOLT MECHANISM
- C - WITH 20 VOLT MECHANISM
- D - WITH 25 VOLT MECHANISM
- E - WITH 110 VOLT MECHANISM

Two Arm Lower Quadrant Bracket or Bridge Signals

Two Arm
Lower Quadrant Bracket or Bridge Signals
Model 2A, Top-of-Mast Mechanism

Unless otherwise specified, signal will be furnished as illustrated on opposite page. Lamps and number plates are not included. If signal other than that shown is desired, specify height to center of blades and give reference numbers to spectacle and blade, also state number and color of roundels. See Part 18 of this Section for spectacles, blades and roundels and Part 17 for masts, ladders, bearings, etc.

Circuit controllers are equipped with the contacts necessary for the local control of the signal only. If pole changing contacts or extra drag contacts are required, same must be specified. State the positions of the signal blade at which each extra contact is to make and break, considering the stop position as 0 degree.

Drawing references are shown for convenience in checking shipping lists and invoices.

Fig. No.	Name	Drawing Reference
Order by plate, figure number and name		
A	Two Arm Lower Quadrant Model 2A Bracket or Bridge Signal, with 8 volt Mechanism complete as shown. For details and specifications of Signal Mechanism see Plate H0901.	
A1	as above, except without Roundels.	
B	same as Fig. A, except with 10 volt Mechanism.	
B1	as above, except without Roundels.	
C	same as Fig. A, except with 20 volt Mechanism.	
C1	as above, except without Roundels.	
D	Two Arm Lower Quadrant Model 2A Bracket or Bridge Signal, with 25 volt Mechanism, complete as shown. For details and specifications of Signal Mechanism see Plate H0903.	
D1	as above, except without Roundels.	
E	same as Fig. D, except with 110 volt Mechanism.	
E1	as above, except without Roundels.	
1	Model 2A 8 volt Signal Mechanism Complete, includes Clamp Bearing, for Fig. A. For details and specifications see Plate H0901 Fig. A.	
1a	same as Fig. 1, except 10 volt, for Fig. B.	
1b	same as Fig. 1, except 20 volt, for Fig. C.	

Two Arm

Lower Quadrant Bracket or Bridge Signals

Model 2A, Top-of-Mast Mechanism

Drawing references are shown for convenience in checking shipping lists and invoices.

Fig. No.	Name	Drawing Reference
Order by plate, figure number and name		
2	Model 2A 25 volt Signal Mechanism Complete, includes Clamp Bearing, for Fig. D. For details and specifications see Plate H0903 Fig. A.	
2a	same as Fig. 2, except 110 volt, for Fig. E.	
3	Mast, 19'-0" long of 5" pipe, drilled for Wire Outlets, includes R. S. A. Base, for Figs. A to E inclusive. For details see Plate H1701.	31499
4	Ladder Complete, includes Hand Rails, Platforms, Stays, Clamps and Bolts, for Figs. A to E inclusive. For details see Plate H1703.	33993